

D3O[®] FITTED ANKLE GUARD

D3O[®] FITTED ANKLE GUARD

D3O uses patented, patent-pending and proprietary technologies to make rate-sensitive, soft, flexible materials with high shock absorbing properties.

The D3O[®] Fitted Ankle Guard offers increased protection and comfort through a more ergonomic shape and tapered profile. This allows for subtler integration into the boot without compromising on performance.

The D3O[®] Fitted Ankle Guard meets CE standard EN 13634 under 5kn transmitted force outside of boot.

PRODUCT FEATURES

- D3O[®] patented technology
- Low profile
- Tapered
- Meets CE EN 13634 standard
- Ergonomic curvature
- Coverage exceeds minimum CE area (suitable for all boot sizes)
- Low impact on aesthetics and functionality of boot
- Increased comfort
- Added protection to ankle area



POTENTIAL INTEGRATION



LOW PROFILE AND FLEXIBLE



ERGONOMIC CURVATURE



©2021 Design Blue Limited. All rights reserved.

Values shown represent typical product characteristics. For full details including material properties and product tolerances, please request SOQ document from D3O representative. The information provided is not intended to and does not create any warranties, expressed or implied, including any warranty of merchantability of fitness for a particular purpose. In accordance with the Company's policy of continuous improvement, D3O reserves the right to apply such improvements to its products and materials without notice. This data sheet shall not be reproduced or amended without the written consent of Design Blue Limited.

TRUSTED IMPACT PROTECTION™

D30® FITTED ANKLE GUARD

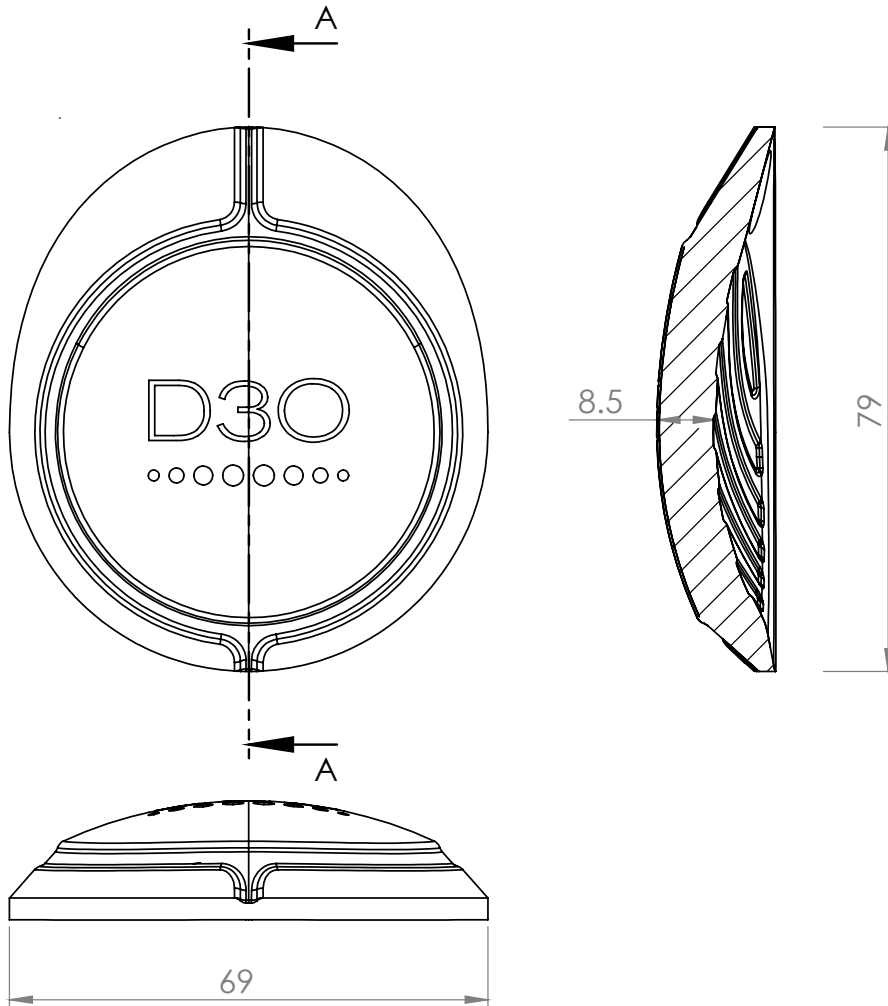

D30® Fitted Ankle Guard - Product Details

Product Name	D30® Fitted Ankle Guard
Product Code	12424
Material Code	SF001
Dimensions (mm)	79 x 69
Thickness (mm)	8.5
Weight (g)	100

©2021 Design Blue Limited. All rights reserved.

Values shown represent typical product characteristics. For full details including material properties and product tolerances, please request SOQ document from D30 representative. The information provided is not intended to and does not create any warranties, expressed or implied, including any warranty of merchantability of fitness for a particular purpose. In accordance with the Company's policy of continuous improvement, D30 reserves the right to apply such improvements to its products and materials without notice. This data sheet shall not be reproduced or amended without the written consent of Design Blue Limited.

Independent testing to EN 13634



TRUSTED IMPACT PROTECTION™